

LEISTER

PROCESS HEAT

IGNITER BM4/BR4

The hot-air blowers for
installation in pellet and
wood chip boilers

NEW!
IGNITER BR4
with 3.4 kW



reddot design award
winner 2013

www.leister.com

We know how.

IGNITER BM4 / BR4 – Ignites just about anything

The new IGNITER ignition blower from Leister has been specially developed for installation into pellet and wood chip boilers. The design and perfectly coordinated functionality will not fail to impress. The IGNITER BM4 with 0.6 up to 1.6 kW and the new IGNITER BR4 with 3.4 kW have what it takes. The interfaces were selected so that the ignition blowers can be easily installed into any heating boiler. The integrated assembly supports on the sides of the

Advantages

| | | |
|---|---|--|
| 1 |  | Easy: Connector plug located directly on the device means easy removal and installation and fewer device configurations. |
| 2 |  | Clever: New assembly support for positioning in the furnace. |
| 3 |  | Linked: Connection adapter for air hose located directly on the device with inner 1" thread (no extra accessories needed). |
| 4 |  | Additional: Pipe joint adapter with M14 thread for easy adaptation of the heat conduction lines and extensions (available only for IGNITER BM4). |
| 5 |  | Protected: Heating element protection with phototransistor and device protection via temperature protection circuit. |



reddot design award
winner 2013

NEW!



housing. The freely configurable plug connector and the air hose connection adapter with one-inch inner thread are innovative measures ensuring optimum installation into heating boilers of all categories.



Clean ignition process due to optimum heat level.

Technical Data

| | | IGNITER BM4 | | | | BM4 BR4 with M14 screw adapter | | | |
|---------------------------------------|--------|-------------|---------|---------|---------|---|---------|---------|-----|
| Voltage | V | 120 | 120 | 230 | 230 | 230 | 230 | 230 | 230 |
| Frequency | Hz | 60 | 60 | 50 | 50 | 50 | 50 | 50 | 50 |
| Power rating | W | 1100 | 1550 | 600 | 1100 | 1600 | 1100 | 3400 | |
| Min. air volume (20° C) | l/min | 230 | 230 | 80 | 230 | 230 | 230 | 230 | |
| Air pressure | kPa | 2.48 | 2.48 | 0.3 | 2.48 | 2.48 | 2.48 | 2.48 | |
| Max temperature | °C | 600 | 600 | 500 | 600 | 600 | 600 | 600 | |
| Emission level | dB (A) | 68 | 68 | 58 | 68 | 68 | 68 | 68 | |
| Aperture | mm ø | 90 | | | | | | | |
| Length | mm | 283 | | | | | | | 294 |
| Weight (without power supply cord) | kg | 1.0 | | | | | | | 1.2 |
| Conformity | | | | | | | | | |
| Safety standard | | | | | | | | | |
| Certification | | CCA | | | | | | | |
| Protection class II | | | | | | | | | |
| Article no. | | 141.882 | 141.881 | 139.232 | 140.711 | 139.231 | 144.012 | 146.296 | |

We reserve the right to make technical changes.
Plug for cable connection and cable are not included.

Accessories

| | | |
|--|----------------------|---|
| | 142.359 | Accessory adapter to TRIAC S Economy heating pipe |
| | 142.414 | Accessory screw adapter for M14 extensions |
| | 107.286 | Air hose ø 38 mm / ø 1.5 in |
| | 107.287 | Hose bracket |
| | 136.916 | Heating element 230V ~ 1550W |
| | 141.002 | Heating element 230V ~ 1050W |
| | 141.003 | Heating element 230V ~ 550W |
| | 136.918 | Heating element 120V ~ 1500W |
| | 141.005 | Heating element 120V ~ 1050W |
| | 145.606 | Heating element (BR4) 230V ~ 3300W |
| | 142.967 | Power supply cord (Rubber) with WAGO Plug 3 x 1 mm² x 3 m |
| | 143.131 | Power supply cord (Silicone) with WAGO Plug 3 x 1 mm² x 3 m |
| | 142.976 | Plug with strain relief, kit (WAGO 770) cable ø 4.5–8 mm |
| | 148.429 (BR4) | Plug with strain relief, kit (WAGO 770) cable ø 8–11.5 mm |

Installation dimensions in mm

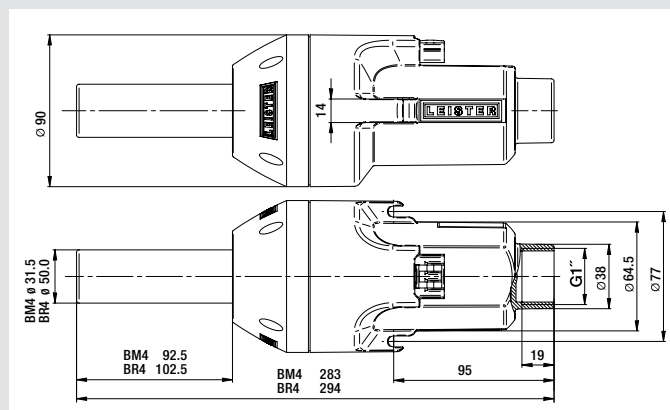

Installation arrangement

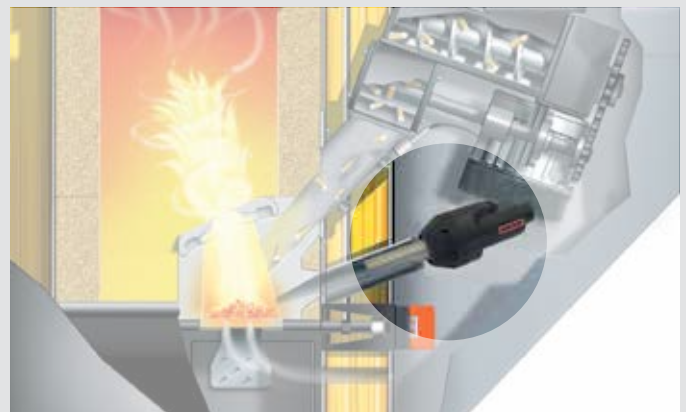



We are local. Worldwide.

Leister Technologies AG
Galileo-Strasse 10
CH-6056 Kaegiswil / Switzerland
phone: +41 41 662 74 74
fax: +41 41 662 74 16
leister@leister.com

Leister Technologies LLC
Itasca, IL 60143 / USA
phone: +1 630 760 1000
info@leisterusa.com

Leister Technologies Ltd.
Shanghai 201 109 / PRC
phone: +86 21 6442 2398
leister@leister.cn

Leister Technologis KK
Yokohama 222-0033 / Japan
phone: +81 45 477 36 37
info@leister.co.jp

Leister Technologies Benelux BV
3991 CE Houten / Nederland
phone: +31 (0)30 2199888
info@leister.nl

Leister Technologies India Pvt
600 041 Chennai / India
phone: +91 44 2454 3436
info@lipipolymers.com

Our dense worldwide network of more than 120 Sales and Service Centres in more than 90 countries.

Europe:

- Austria
- Belarus
- Belgium
- Bulgaria
- Croatia
- Cyprus
- Czech Republic
- Estonia
- Denmark
- Finland
- France
- Germany
- Great Britain
- Greece
- Hungary
- Ireland
- Iceland
- Italy
- Kazakhstan
- Latvia
- Lithuania
- Netherlands
- Norway
- Poland
- Portugal
- Romania
- Russia
- Serbia
- Slovakia
- Slovenia
- Spain
- Sweden
- Switzerland
- Turkey
- Ukraine

America:

- Canada
- Mexico
- USA
- Argentina
- Brazil
- Chile
- Columbia
- Costa Rica
- Ecuador
- Venezuela
- Peru

Africa:

- Algeria
- Egypt
- Kenya
- Morocco
- South Africa
- Tunisia

Middle East:

- U.A.E.
- Saudi Arabia
- Qatar
- Iran

Asia Pacific:

- P.R.China
- Hong Kong
- India
- Indonesia
- Japan
- Korea
- Malaysia
- Mongolia
- Philippines
- Singapore
- Taiwan
- Thailand
- Vietnam

Oceania:

- Australia
- New Zealand

© Copyright by Leister, Switzerland

Distributor addresses: