

WELDPLAST 300

Operating Instructions



Table of Contents

1. Application	4
1.1 Intended use	4
1.2 Non-intended use	4
1.3 Safety and protective measures	5
2. Technical data	7
3. Transport	8
4. Your WELDPLAST 300	9
4.1 Type plate and identification	9
4.2 Scope of delivery (standard equipment in the case)	9
4.3 Overview of device parts	10
5. Settings on the WELDPLAST 300	11
5.1 Additional handle	11
5.2 Change of welding shoes	11
5.3 Welding direction	12
6. WELDPLAST 300 operation	13
6.1 Work environment and safety	13
6.2 Resting position	13
6.3 Preparation	13
6.4 Starting the device	14
6.5 Welding sequence	14
6.6 Finishing welding	15
6.7 Switch off the device	15
7. WELDPLAST 300 Quick Guide	16
7.1 Switching on/Starting	16
7.2 Switching off	16
8. The WELDPLAST 300 control panel	17
8.1 Function buttons	17
8.2 Display	18
8.3 Setting the welding parameters	18
8.4 Display symbols of the status display (Display 35)	19
8.5 Display symbols of the work display (Display 35)	20

9. Settings and functions of the software of the WELDPLAST 300	21
9.1 Menu navigation overview	21
9.2 Overview menu navigation Advanced Mode	23
9.3 Recipes	25
9.4 Displaying nominal values (Set values)	26
9.5 Eco mode	27
9.6 LOS Data Recording settings	28
9.7 WLAN settings	31
9.8 Machine settings	31
9.9 Info mode	35
9.10 Duty info	35
9.11 General Info	35
10. WELDPLAST 300 Warning and Error Messages	36
11. Accessories	38
12. Maintenance	38
13. Service and repair	39
14. Training	40
15. Other applicable documents	40
16. Declaration of Conformity	40
17. Disposal	40

Congratulations on purchasing your WELDPLAST 300.

You have chosen a first-class hot-air welding extruder.

It was developed and produced in accordance with the latest state-of-the-art technology in the plastics-processing industry. It has also been manufactured using high-quality materials.



Please read the operating instructions before operating.

WELDPLAST 300

Hot Air Welding Extruder



To learn more about the WELDPLAST 300, visit leister.com

1. Application

1.1 Intended use

The WELDPLAST 300 is intended for professional, manual welding of thermoplastics made of PE and PP in the areas of container, pipeline, apparatus and landfill construction, as well as for repairs.

Welding procedures and types of materials

- Only for welding thermoplastic materials based on polyethylene and polypropylene (PE-LD, PE-HD, PP).

1.2 Non-intended use

Any other use or any use beyond the type of use described is deemed non-intended use.

1.3 Safety and protective measures

Please observe the safety instructions provided in the individual chapters of these operating instructions as well as the following safety instructions.

Danger



Electrical Shock Danger - Protect yourself from electrical shock.

- Caution when welding in an electrically conductive environment (dust and fibers).
- The device is only to be connected to sockets and extension cables with a protective earth conductor.
- Protect the device from moisture and wet conditions.
- When used on a construction site, a residual current circuit breaker is mandatory.
- Prior to using the device for the first time, check the power cord, the plug, and the extension cable for electrical and mechanical damage.
- The device may only be opened by trained personnel, since live parts are exposed when the device is opened.



Fire and Explosion Hazard – Be aware of the hazard when used improperly in the presence of flammable materials and/or explosive gases.

- Be careful not to burn the material during the welding process.
- Never place the device near combustible materials and/or explosive gases.
- Never place the device close to combustible materials and/or explosive gases while it is running and/or hot.
- Place the hot-air extruder on a fire-resistant surface. Make sure that hot parts of the device and the hot air jet are sufficiently clear of the surface.
- Use only a designated device position as a resting position.



Health Hazard – Protect yourself when machining plastics.

- When welding with incorrect materials or when welding at too high a temperature, a risk of harmful gases/vapors can arise.
- Avoid breathing vapors.
- Follow the material manufacturer's specification.
- Always ensure good ventilation of the workplace when working.



Risk of Combustion – Be aware of the risk of hot equipment parts, leaking mass or hot air jet.

- Do not touch bare metal parts and leaking mass in hot condition.
- Never point the hot air jet or the escaping mass at people or animals.
- Allow the unit to cool completely before decommissioning.



Glare Hazard – Be aware of the risk of light beams.

- Avoid looking directly into the light beam.



Danger of death from improperly repaired equipment.

- Have **repairs** performed only by an authorized service center.
- **Only original accessories** and **spare parts** may be used.



Trip hazard if the power cord is not carefully placed.

- Note that there is a risk of tripping when the mains connection line is not installed carefully.
- Make sure that the mains cable is free to move and does not interfere with the users or third parties at work.



Danger of retraction due to unintentional collection and indentation of clothing or body parts.

- Do not wear loose clothing such as scarves or cloths. Tie up long hair or protect it by wearing headgear.

Caution



- Only operate the device **under supervision**, as the resulting waste heat can ignite flammable materials.
- The device should only be operated by **trained specialists** or under their supervision.
- Children are not permitted to operate the device.





- Note that the nominal voltage specified on the device must match the **local line voltage**.



- Use safety glasses.

2. Technical data

WELDPLAST 300

Voltage	V	230
Frequency	Hz	50/60
Power	W	3680
Temperature	°C Plast	Max. 260
	°C Air	Max. 320
	°F Plast	Max. 500
	°F Air	Max. 608
Adjustable air volume		Yes
Air quantity preheating air	%	45-100
Drive	%	60-100
Welding rod (in acc. with DVS 2211)	mm	Ø3-Ø4 ± 0.3
Output with Ø3	kg/h	1.0-2.0
Output with Ø4	kg/h	1.8-3.2
Welding materials		PE-LD; PE-HD; PP
Noise level	dB (A)	< 78 (K = 3)
Vibration level	ah (m/s ²)	< 2.5 (K = 1.5 m/s ²)
LOS		Yes
Wi-Fi radio properties		
RF frequency range	GHz	2 400-2 4835
Transmission power 802.11 g	dBm	15 ± 1
Brushless blower motor		Yes
Brushless Drive Motor		Yes
Length	mm	525
	in	20.6
Width	mm	115
	in	4.5
Height	mm	270
	in	10.6
Weight	kg	7.0
	lbs	3.2
Approvals, protection class		 
Country of origin		Switzerland

We reserve the right to make technical changes.

3. Transport



Risk of excessive physical strain when carrying and lifting the device

- The weight of your WELDPLAST 300 including transport box is approx 11 kg (7 kg without transport box).
- For transporting the WELDPLAST 300, use only the transport box included in the scope of delivery (see scope of  delivery [4.2]).
- Observe applicable regulations for carrying or lifting loads.



Fire hazard when transporting while hot

- Therefore, it is important to allow the device to cool sufficiently before transport (see  Cool-Down Mode [6.7]).
- Never store flammable materials (such as plastic or wood) in the transport box.



- Do not use the WELDPLAST 300 or the transport box for transport with a crane.

4. Your WELDPLAST 300

4.1 Type plate and identification

The model and serial number are indicated on your device's **name plate (5)**. Please include this information in your user manual and refer to our country company or your authorized Leister sales and service partner.

Model:
Serial no.:

Example:



4.2 Scope of delivery (standard equipment in the case)

- 1 × WELDPLAST 300
- 1 × Safety Instructions
- 1 × Quick Reference Guide

4.3 Overview of device parts

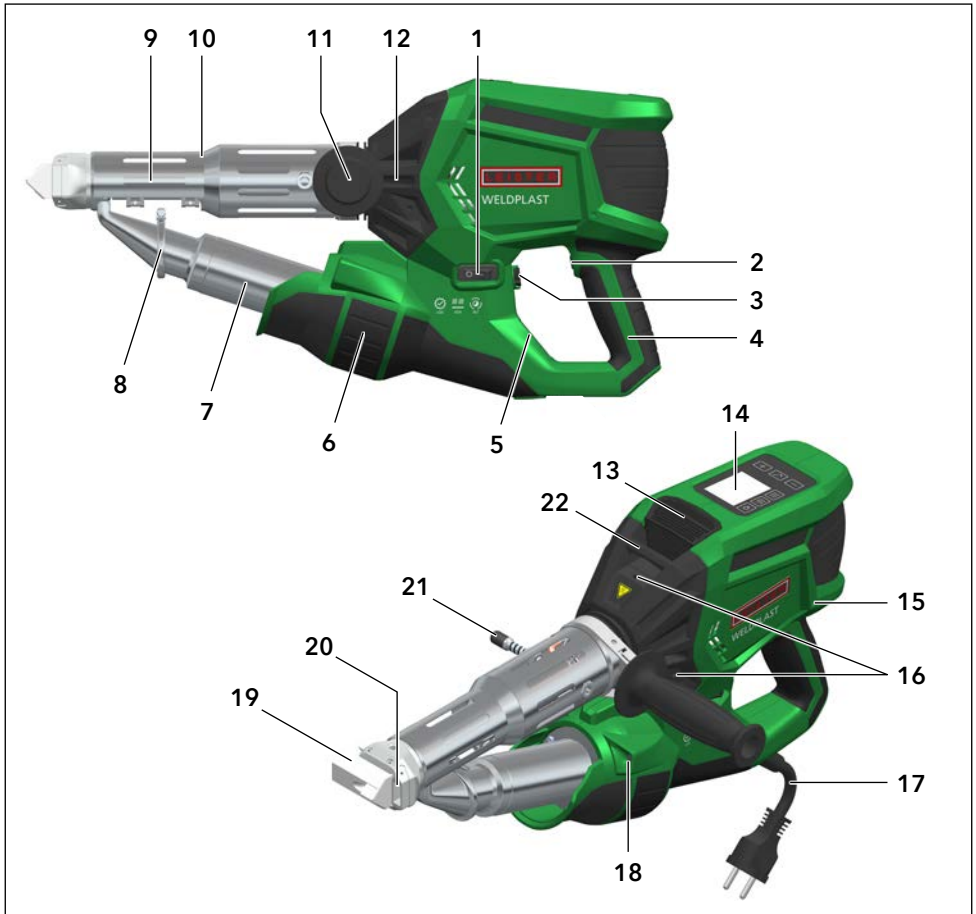

- | | |
|------------------------------------|---|
| 1. Main switch | 12. Welding rod insertion (both sides) |
| 2. Drive On/Off Switch | 13. Supply air filter |
| 3. Potentiometer output regulation | 14. Control panel |
| 4. Device Handle | 15. Mounting holes (2 × for plastic screw 35) |
| 5. Type plate | 16. Fastening thread (3 × M6) |
| 6. Heat guns | 17. Power cord |
| 7. Heating element protective tube | 18. LED lighting |
| 8. Tube clamp | 19. Welding shoe |
| 9. Jacket heating | 20. Preheating nozzle |
| 10. Protective tube | 21. Support |
| 11. Additional handle | 22. Hanging Point |

5. Settings on the WELDPLAST 300

5.1 Additional handle

Loosen the clamp by turning the **additional handle (11)** counterclockwise. Adjust the position of the **additional handle (11)** to your preference. Then tighten the clamp again by turning the **additional handle (11)** clockwise.

The **additional handle (11)** can be removed by unhooking the tab.



5.2 Change of welding shoes



Risk of burns when touching the hot welding shoe

- Only work with heat protection gloves.



Fire hazard due to hot welding shoe

- Note that the hot **welding shoe (19)** can ignite combustible materials.
- Place the hot **welding shoe (19)** on a fireproof surface.



Risk of equipment damage due to hot air jam

- Note that an incorrect or defective **welding shoe (19)** can lead to a build-up of hot air, which damages the device.
- Only use suitable original Leister welding shoes for the device.

Removal

- Switch off the operating warm device and disconnect it from the electric power supply.
- Remove the **welding shoe (19)** by loosening the **clamping screws (24)** and removing the welding shoe from the **extruder nozzle (23)**.
- Clean the **extruder nozzle (23)** carefully with a brass brush of welding material residues each time the welding shoe is changed and ensure that it is screwed in place.

Note: Extruder nozzle (23) is left-hand thread.

Assembly

- Slide a **welding shoe (19)** adapted to the welding seam onto the **extruder nozzle (23)** and fasten it by tightening the **clamping screws (24)**.

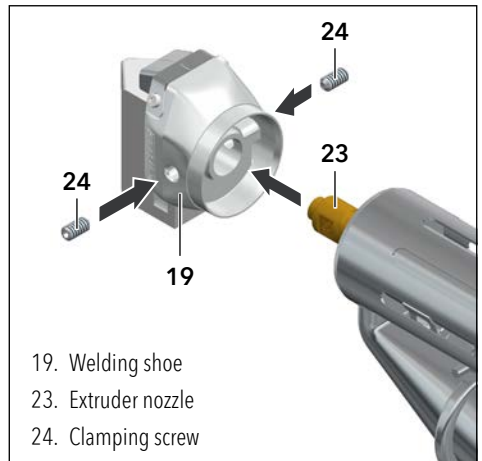

5.3 Welding direction

The **welding shoe (19)** can be aligned according to the desired welding direction by loosening the two **clamping screws (24)** before welding. Then retighten the two **clamping screws (24)**.

Note that the **nozzle preheated air (20)** must always be in the welding direction (arrow in the images below) in front of the **welding shoe (19)**.

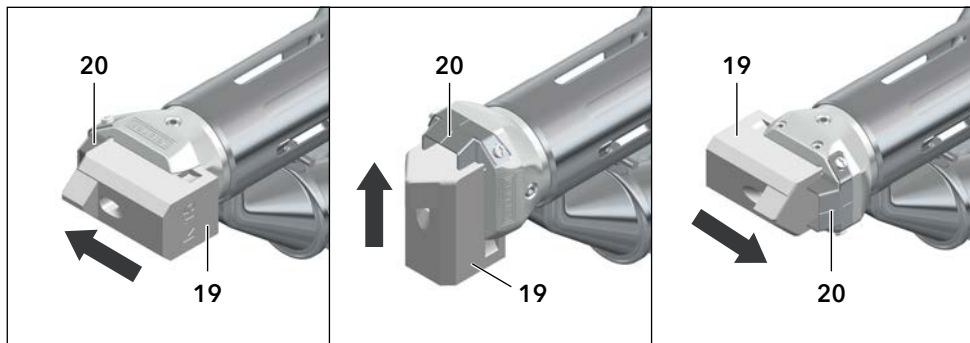

6. WELDPLAST 300 operation

6.1 Work environment and safety

Power cord and extension cable

- The nominal voltage specified on the device (see [E3](#) Technical Data [2]) must match the mains voltage.
- The extension cables must be authorized for the utilization site (such as, outdoors) and be marked accordingly. Take the necessary minimum cross-section for extension cables into account. Recommendation minimum 1.5 mm²/ AWG16.

Power supply with autonomous power generators

- The formula "2 × nominal output of the hot-air extruder" applies to the design of the nominal output of power generators.
- Do not turn the unit on or off unless the generator is running, as this may damage the electronic components.
- Disconnect the device from the mains before starting or shutting down the generator.

6.2 Resting position

The following device positions are intended as a resting position:

- Place the device on the original Leister device stand accessories. Make sure that the power cord is routed backward in the dedicated recess on the unit and is not kinked or pinched between the unit and the unit stand.
- Place the device on the side of the tightened **additional handle (11)** or on the **support (21)** so that the **welding shoe (19) / nozzle points preheated air (20)** upwards in the air and does not touch any objects or the surface. The **support (21)** can be mounted on either side of the unit.



6.3 Preparation

- Check whether the welding rod and the material to be welded are clean and compatible.
- Check whether the **welding shoe (19)** is clean and corresponds to the application.
- Check whether the **welding shoe (19)** is in the appropriate position for the welding seam and has been tightened.

6.4 Starting the device

- Once you have prepared the working area and the hot air welder in accordance with the description, connect the hot air welder to the supply voltage.
- Use the **main switch (1)** to switch the hot-air welder extruder on.



After starting, the display will briefly display the start screen with the current software version number and the device name.

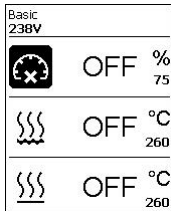

If the device was allowed to cool down beforehand, this will be followed by a static display of the set values of the most recently used profile (the Basic profile is displayed when the device is first commissioned).

The heating is not yet switched on at this stage.

- Select the appropriate welding recipe (see 9.3) or set the welding parameters individually.
- Now switch on the heating using the *Heating On/Off button (31)*.

6.5 Welding sequence

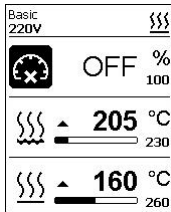

Preparing for welding

Once you have turned on the heating (button 31 *Heating On/Off*), you will receive a **dynamic display of the current air and plast temperature with progress bars** (target and actual values).

The plastic drive is still locked.

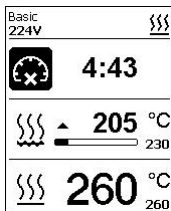

If the ACTUAL temperature of the Plast is 30°C below the TARGET temperature, the 5-Minuten-Timer. If the timer has expired, the Plast drive is released.

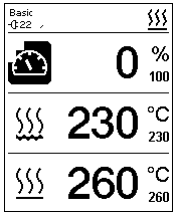

The plastic and air temperatures have now been reached. The plastic drive is enabled.

- Now carry out test welds in accordance with the welding instructions of the material manufacturer and/or national standards or regulations and inspect the results. Adjust the welding profile as required.
- By pressing the **drive on/off switch (2)**, the plastic drive starts extruding the inserted welding rod.
- Before the actual welding, you extrude some material without welding.
- **Guide the extruder during the welding process keeping it stable. The nozzle preheat air (20) must specifically heat the surfaces to be welded.**
- Never insert the welding rod into both **welding rod insertions (12)** at the same time. Always operate the extruder with welding rod.
- Do not operate the hot-air extruder for a longer period of time at the speed selected too low. Otherwise, there is a risk that the drive will overheat.

6.6 Finishing welding

- To stop the plast output, press the **drive on/off switch (2)**. Then slowly and slidably swing the welding shoe away from the weld seam. Pull any remaining material out of the welding shoe hole.

6.7 Switch off the device

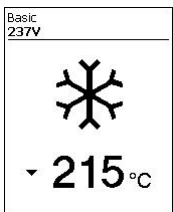

- Cut off the welding rod.

Switch off the *air/plastic heaters* with button 31. Cool-down mode will be enabled.

- Note that the **jacket heating (9)** from the plast remains hot for a certain time after the cool-down mode has been completed.
- The blower switches off automatically after approx. 6 minutes.
- Then switch off the device with the **main switch (1)** and disconnect the **power supply cable (17)** from the electrical mains.
- Wait until the device has cooled down fully.

7. WELDPLAST 300 Quick Guide



Observe the safety instructions and warnings in the individual sections of these operating instructions.

7.1 Switching on/Starting

1. Make sure that the **main switch (1)** is switched off and that the mains **connection cable (17)** is connected.
2. Turn on the **main switch (1)**.
3. Switch on the heating using the *Heating On/Off* button (31).
4. Wait 10 minutes until the desired temperature is reached and the drive is released.
5. Insert the welding rod into the **welding rod insertion (12)** and switch on the plastic drive with the **drive on/off switch (2)**.

7.2 Switching off



1. Cut off the welding rod.
2. With the plastic drive switched off, clean the opening of the welding shoe.
3. Switch off the heating using the *Heating On/Off* button (31) and wait until the end of the cooling process (approx. 5 minutes).
4. Turn off the **main switch (1)**. **Caution: Jacket heaters (9)** and the **protection tube (10)** connected thereto remain hot for some time.
5. Unplug the **power cord (17)**.











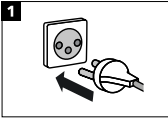

WELDPLAST 300 Quick Guide

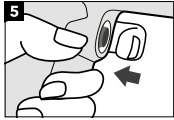
Operating Instructions: leister.link/qg-weldplast-300

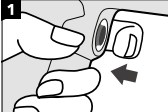
Download myLeister App (to use LQS)

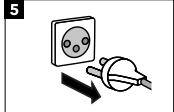

 1 	2 	3 	4 10 min 	5 
 1 	2 	3 6 min 	4 	5 

QG WELDPLAST 300 / 02.2025 / 141.355

8. The WELDPLAST 300 control panel





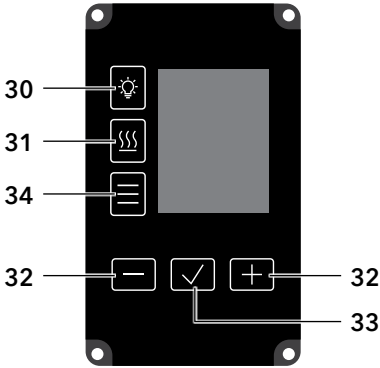

The **control panel (14)** consists of the **function buttons (30-34)** used to control the various menu functions, as well as the **display (35)** that displays the selected setting, menu options or the values valid at run time.

8.1 Function buttons



- 30. Button *Work Light On / 50% / Off*
- 31. Button *Heating On/Off*
- 32. Button *Minus/Plus*
- 33. Button *Confirm*
- 34. Button *Menu*
- 35. Display

Multiple assignment function buttons control panel (2) / symbols display

Symbol	Name	in the work display	In the menu, after pressing the button (32)
	Work light button On / 50% / Off (30)		
	Button Heating On/Off(31)		
	Minus/Plus Buttons (32)		
		press briefly	Set desired set point in 5°C or 5% increments
		press and hold	Quickly set desired set point
			Changing the position/changing the menu, setting parameters
			Changing the position/changing the menu, setting parameters
	Button Confirm (33)	The set value is applied and shown in the Menu selection.	The desired function or menu is executed.
	Button Menu (34)	Switching to the menu area	back to working display

8.2 Display

The display is subdivided into two display areas:

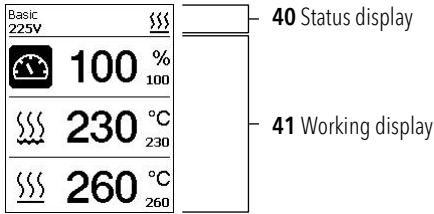

8.3 Setting the welding parameters

To adjust a welding parameter before welding, proceed as follows:

Example for setting the welding temperature

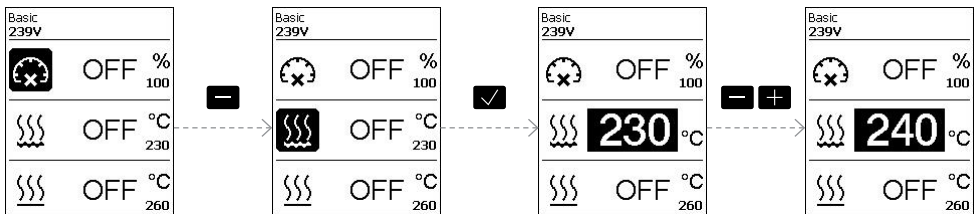

- Press the *Minus* button (32) to select *Plast* temperature
- Then press the *Confirm* button (33)
- Set the desired temperature setpoint with the *minus/plus* (32) buttons
- without further input, cursor automatically jumps back to temperature symbol
- select the next welding parameter with the *minus/plus* (32) buttons

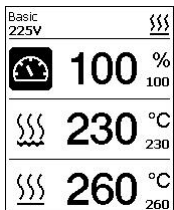

- During the welding process, the *plast* output can be adjusted between 60 and 100% at any time by means of a **potentiometer output regulation (3)**
- To adjust other parameters, press *Minus/Plus* (32) to select the parameter to adjust

- Pressing the *Confirm* button (33)
- then use the *Minus/Plus* (32) buttons to set the desired target value
- without further input, cursor automatically jumps back to temperature symbol

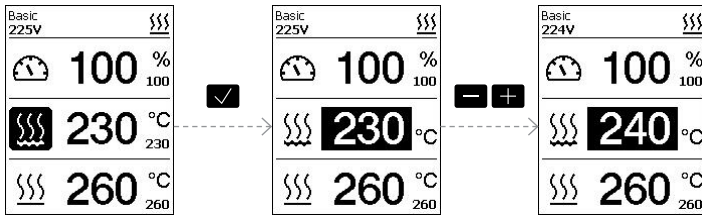

8.4 Display symbols of the status display (Display 35)

The Status display is subdivided into a left-hand (1) and a right-hand area (2).

Status indicator 1/left	
Profile name	Displays the name of the selected currently valid welding profile (such as Basic). If a profile name contains more than six characters, the first six characters and then the remaining six characters. The system then represents the first six characters.
Voltage	Display of the supply voltage
Status indicator 2/right	

	Warning present		Data recording		Overvoltage
	Eco mode		GPS data reception		Undervoltage
	WLAN		Stop Device on Alert switched on		Heating

8.5 Display symbols of the work display (Display 35)

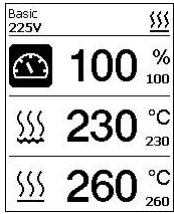

During operation, the target values of the welding parameters (output in %, Temperature in °C or °F, air volume in % and, if necessary, Information notes (see [E3](#)) Displaying target values [Set Values] [9.4]).

- Change welding parameters using the *Minus/Plus* button (32)
- After pressing the *Confirm* button (33), the selected parameter can be individually adjusted using the Minus/ Plus button (32).



Plastic ejection symbol [%]



Plastic temperature symbol [°C or °F]



Symbol air temperature [°C or °F]



Symbol air volume [%]



Welding temperature too low, heat-up process.

- **Up arrow** and progress bar indicate when **higher temperature** is not yet reached.
- Blinking value above progress bar denotes current actual value (205).
- Value to the right of the bar (230) shows the target value of the selected welding profile or individual setting.



Temperature too high, cool-down process.

- **Down arrow** and progress bar indicate when desired **lower temperature** is not yet reached.
- Flashing value above the bar denotes the actual value currently achieved (240).
- Value to the right of the bar (215) shows the target value of the selected welding profile or individual setting.



Symbol for cool-down mode



Symbol for **hardware error warning**

- Device no longer ready for use
- Contact an authorized Leister Service Center (note the respective error code in the [E3](#) section Warning and error messages)



Symbol for **hardware error warning** (heating element is defective).

- Device no longer ready for use
- Contact an authorized Leister Service Center



Symbol for **Overtemperature warning message**.

Allow the device to cool down.

9. Settings and functions of the software of the WELDPLAST 300

9.1 Menu navigation overview

Pressing the  *Menu button (34)* takes you to the Basic Settings menu items.



From the default setting, use the Settings menus to access formulas, display setpoints, Eco Mode, LQS and Advanced Mode.

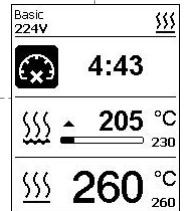
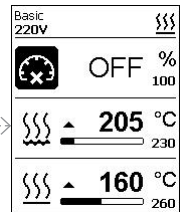
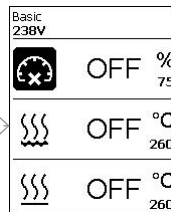
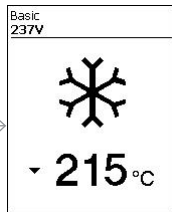

Recipes (see 9.3)

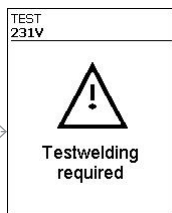
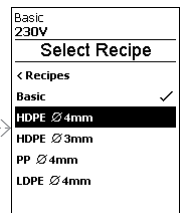
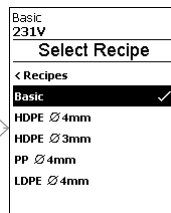

Switch off target and actual value display (see 9.4)

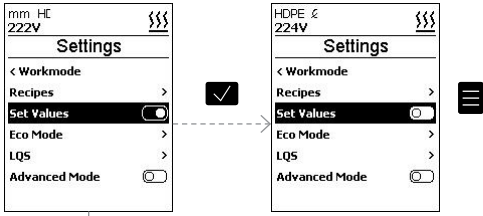

Switching on Eco-Mode (see 9.5)

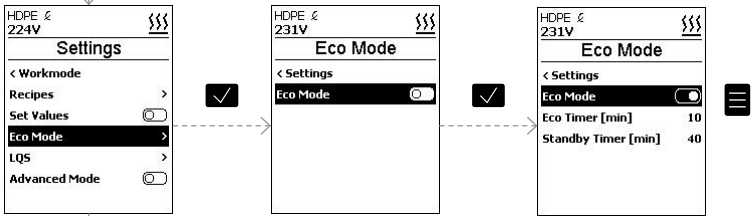

Switch on data recording (see 9.6)

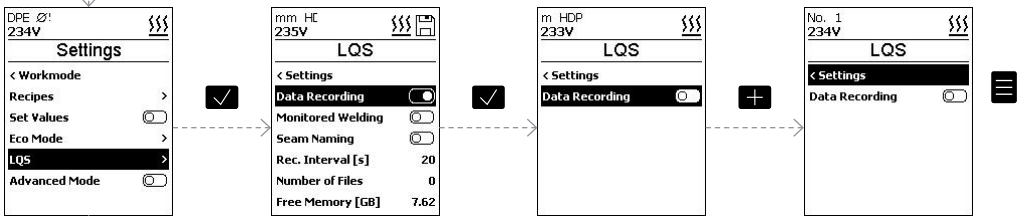

Switching on Advanced Mode

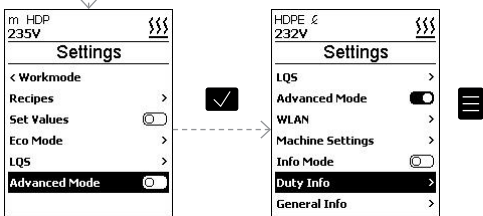

Note: Pressing the  Menu (34) button will return you to the working display in each menu item.

9.2 Overview menu navigation Advanced Mode



If you activate Advanced Mode, further information and setting options are available. WLAN, machine settings, info mode, counter, general info, warnings

Switching on Advanced Mode

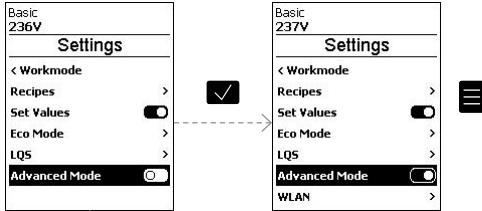

Enable Wi-Fi (see [9.7](#))

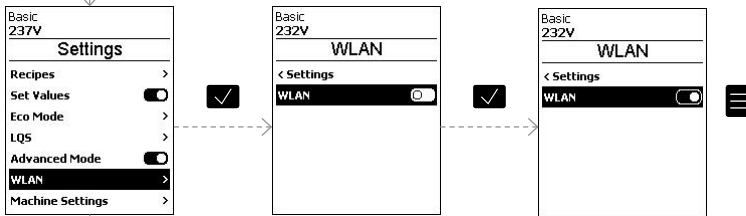

Machine settings (see [9.8](#))
Example: Setting the time

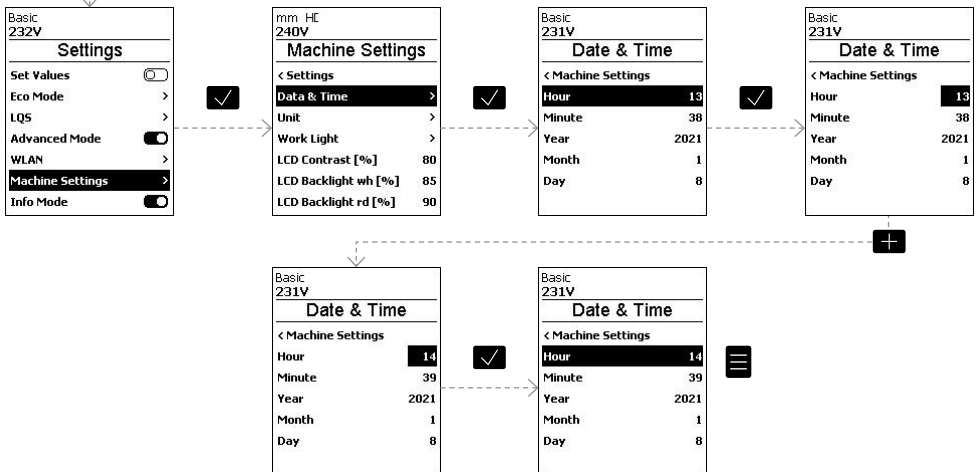

Switching on Info Mode (see 9.9)

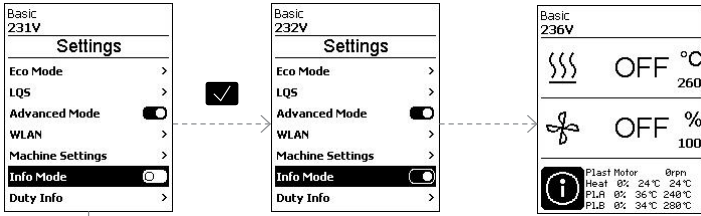

Counter (see 9.10)

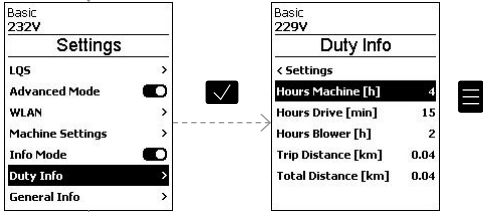

General Info (see 9.11)

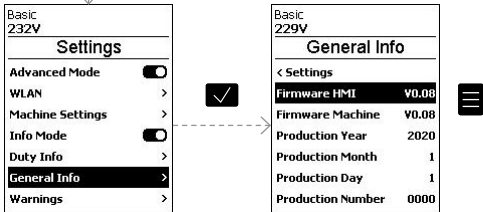

Warnings (see 10)

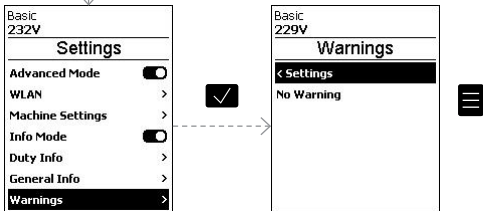

Note: Pressing the Menu (34) button returns you to the working display in each menu item

9.3 Recipes



- Recipes saved recipes can be found under Select
- To select a recipe, press the *Confirm button* (33).
- If no recipes are available, you can create recipes under New



- Using the *Minus/Plus* (32) buttons to select the desired recipe
- Press the *Confirm button* (33) to accept the recipe
- Exiting the menu by pressing the *Menu button* (34)
- Note for test welding appears



- You can create a recipe yourself under the New menu item.

- to edit a name, press the *Confirm button* (33)
- select with *Minus/Plus* (32) buttons characters or number and accept with *Confirm* (33) button
- Line change with the buttons *working light* (30) or *heating* (31)
- to exit the character editor and save the name, select Check-Hook and accept with the *Confirm button* (33)

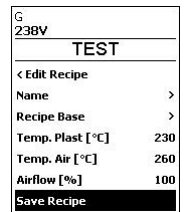
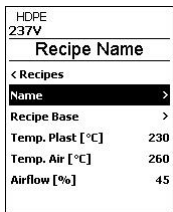

You can adjust the parameters of your own recipes at any time.

- To do this, select the Edit submenu in the Recipes menu by pressing the *Minus* (32) button.
- After pressing the *Confirm* (33) button, all editable recipes are displayed.
- Use the *Minus* button (32) to select the recipe to be edited and press the *Confirm* button (33).
- Use the *Minus* (32) button to select the parameter to be edited and press the *Confirm* (33) button.
- The *Minus/Plus* (32) buttons now allow you to set the desired value.
- Press the *Confirm* (33) button to accept the set value.
- To save the setting, select the menu item Save Recipe with the *Minus* (32) button, then press the *Confirm* (33) button

Basic 228V
Recipes
< Settings
Select >
New >
Edit >
Delete >

Basic 234V
Recipes
< Settings
Select >
New >
Edit >
Delete >

Basic 229V
TEST
< Edit Recipe
Name >
Recipe Base >
Temp. Plast [°C] 230
Temp. Air [°C] 260
Airflow [%] 100
Save Recipe

Basic 230V
TEST
< Edit Recipe
Name >
Recipe Base >
Temp. Plast [°C] 230
Temp. Air [°C] 260
Airflow [%] 100
Save Recipe

Basic 230V
TEST
< Edit Recipe
Name >
Recipe Base >
Temp. Plast [°C] 230
Temp. Air [°C] 260
Airflow [%] 100
Save Recipe

Basic 230V
TEST
< Edit Recipe
Name >
Recipe Base >
Temp. Plast [°C] 230
Temp. Air [°C] 250
Airflow [%] 100
Save Recipe

9.4 Displaying nominal values (Set values)

Basic 233V
Settings
< Workmode
Recipes >
Set Values <input checked="" type="checkbox"/>
Eco Mode >
LQS >
Advanced Mode <input type="checkbox"/>

Factory activated

If the target and actual values are not displayed on the working display, you can deactivate set values by pressing the *Confirm* button (33).

250 °C
230

If the Set Values function is activated (factory setting), the actual temperature (high) and the target temperature (low) are shown in the work display.

This also applies to plastic extrusion (%) and air volume (%).

9.5 Eco mode



Switched off at the factory

- Activate Eco Mode by pressing the *Confirm* (33) button.
- The time interval of the eco and standby timer can be individually configured by selecting the value to be edited with the *Minus/Plus* (32) buttons.
- After pressing the *Confirm* (33) button, the desired value can be individually set with the *Minus/Plus* (32) buttons.
- Pressing the *Confirm* button (33) takes over the set value.

If Eco mode is activated, the plastic heating is switched on first during the heating up process. The air heater is still switched off. When the plastic heater reaches the ACTUAL temperature of 20°C before the set TARGET temperature, the extruder 5-Minuten-Countdown-Timer starts. At the same time, the air heater is switched on. Both heaters are ready for plastic and air until the end of the countdown timer. The air volume is activated as set.

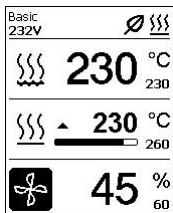

Eco Timer

If the extruder remains below the time period specified in the eco timer when Eco mode is activated, an automatic change to Eco mode occurs. The amount of air is automatically reduced to the minimum and the set point of the air temperature is reduced by 30°C. The working display shows the Eco mode with the corresponding icon.

With **the drive on/off switch (2)** or one of the three buttons **[-]** **[✓]** **[+]**, the operating state can be reactivated at any time.

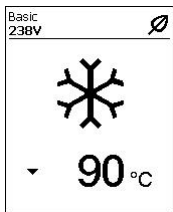

Standby timer

After expiration of the standby timer without activity, the cooling process is initiated. To interrupt the cooling process, press the *Heating On/Off* button (31).

9.6 LQS Data Recording settings

- Select the menu item LQS in the menu by pressing the *Minus* (32) button
- Then press the *Confirm* button (33)
- Press the *Confirm* button (33) to switch on the data recording

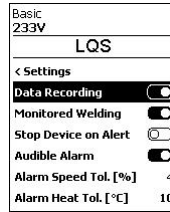
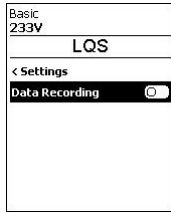

Monitored Welding

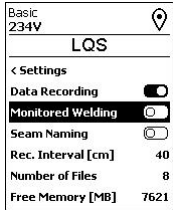

- If Monitored Welding is switched on, limit values of the recorded welding parameters are logged
- In the menu, select the menu item Monitored Welding by pressing the *Minus* (32) button
- Then press the *Confirm* button (33)

Audible Alarm



- If audible alarm is switched on, an acoustic alarm sounds if the limit value is exceeded
- to activate Audible Alarm, select the menu item Audible Alarm in the menu by pressing the *Minus* (32) button, then press the *Confirm* (33) button

- Select the limit value to be set by pressing the *Minus* (32) button, then press the *Confirm* (33) button.
- Set the limit value with the *Minus/Plus* button (32).

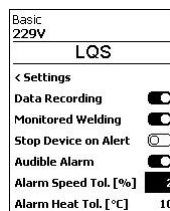
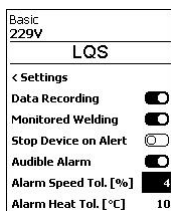

Seam Naming

Basic 236V
LQS
Audible Alarm <input type="checkbox"/>
Alarm Speed Tol. [%] 2
Alarm Plast Tol. [°C] 10
Alarm Heat Tol. [°C] 10
Alarm Vol. Tol. [%] 5
Seam Naming <input type="checkbox"/>
Rec. Interval [s] 20

Basic 236V
LQS
Audible Alarm <input type="checkbox"/>
Alarm Speed Tol. [%] 2
Alarm Plast Tol. [°C] 10
Alarm Heat Tol. [°C] 10
Alarm Vol. Tol. [%] 5
Seam Naming <input checked="" type="checkbox"/>
Seam Name >

- Select Seam Naming by pressing the *Minus* (32) button, then press the *Confirm* (33) button

Seam Name

Basic 236V
LQS
Alarm Speed Tol. [%] 2
Alarm Plast Tol. [°C] 10
Alarm Heat Tol. [°C] 10
Alarm Vol. Tol. [%] 5
Seam Naming <input checked="" type="checkbox"/>
Seam Name >
Rec. Interval [s] 20

Basic 236V
Seam Name
< LQS
Seam Name >

- by pressing the *Minus* (32) button, select Seam Name, then press the *Confirm* (33) button

Basic 230V
SEAM-1
1 2 3 4 5 6 7 8 9 0
Q W E R T Z U I O P
A S D F G H J K L
↑ Y X C V B N M ↵
⏪ ⏩
✓

Basic 236V
Seam Name
< LQS
SEAM-1 >

- to edit the name, press the *Confirm* button (33)
- select characters or numbers with minus/plus (32) buttons, then use the *Confirm* (33) button to accept
- Line change with *drive* (30) or *heater* (31) buttons
- to exit the character editor and save the selected name, select the check mark and accept it with the *Confirm* button (33)

Rec. Interval

Basic 232V
LQS
Alarm Speed Tol. [%] 4
Alarm Heat Tol. [°C] 10
Alarm Vol. Tol. [%] 5
Seam Naming <input type="checkbox"/>
Seam Name >
Rec. Interval [cm] 40
Number of Files 13

Basic 232V
LQS
Alarm Speed Tol. [%] 4
Alarm Heat Tol. [°C] 10
Alarm Vol. Tol. [%] 5
Seam Naming <input type="checkbox"/>
Seam Name >
Rec. Interval [cm] 20
Number of Files 13

- by pressing the *Minus* (32) button, select the menu item Rec. Select Interval, then press the *Confirm* button (33)
- with *Minus/Plus* button (32) set value for recording interval
- Then press the *Confirm* button (33) to accept the set value

Number of Files

Basic 236V	
LQS	
Alarm Heat Tol. [°C]	10
Alarm Vol. Tol. [%]	5
Seam Naming	<input type="checkbox"/>
Seam Name	>
Rec. Interval [s]	15
Number of Files	0
Free Memory [GB]	7.62

- by pressing the *Minus* (32) button, select the menu item Number of Files - the number of recorded files is displayed

Free memory

Basic 236V	
LQS	
Alarm Vol. Tol. [%]	5
Seam Naming	<input type="checkbox"/>
Seam Name	>
Rec. Interval [s]	15
Number of Files	0
Free Memory [GB]	7.62
GPS	<input type="checkbox"/>

- by pressing the *Minus* (32) button, select the Free Memory menu item - the free memory capacity is displayed

GPS

Basic 236V	
LQS	
Alarm Vol. Tol. [%]	5
Seam Naming	<input type="checkbox"/>
Seam Name	>
Rec. Interval [s]	15
Number of Files	0
Free Memory [GB]	7.62
GPS	<input type="checkbox"/>

Basic 237V	
LQS	
Seam Naming	<input type="checkbox"/>
Seam Name	>
Rec. Interval [s]	15
Number of Files	0
Free Memory [GB]	7.62
GPS	<input type="checkbox"/>
GPS Position	>

Switched off at the factory

- To switch on the GPS in the menu, select the menu item GPS by pressing the *Minus* (32) button, then press the *Confirm* (33) button

The GPS coordinates of the welds are now displayed in the welding protocol.

GPS position

Basic 237V	
LQS	
Seam Naming	<input type="checkbox"/>
Seam Name	>
Rec. Interval [s]	15
Number of Files	0
Free Memory [GB]	7.62
GPS	<input type="checkbox"/>
GPS Position	>

Basic 235V	
GPS Position	
N 46° 54.8271'	
Longitude	
E 0° 15.5502'	
Elevation	
468.19 m	
Satellites in view	10
HDOP	1.91

- In the menu, select the menu item GPS position by pressing the *Minus* (32) button, then press the *Confirm* (33) button
- GPS position data can be viewed with an existing satellite connection using the *Minus/Plus* button (32)
- The GPS reception icon is displayed in the **status display (40)**.
- Icon filled in black → Satellites were found
- Icon not filled → searching for Satellites

9.7 WLAN settings

Switched off at the factory



- In the menu, select the menu item WLAN by pressing the *Minus* (32) button, then press the *Confirm* (33) button

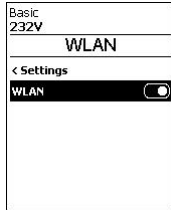
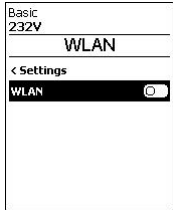

- to switch on WLAN, press the *confirm* button (33)

9.8 Machine settings

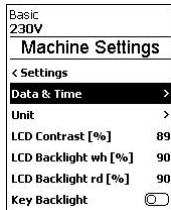

- In the menu, select the menu item Machine Settings by pressing the *Minus* (32) button, then press the *Confirm* (33) button

Date and time setting

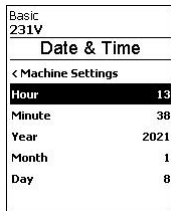
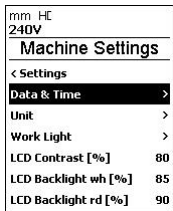

- In the menu, select the menu item Data & Time by pressing the *Minus* (32) button, then press the *Confirm* (33) button
- Hour, minute, year month and day are adjustable
- select the value to be edited with the *Minus/Plus* (32) buttons, then press the *Confirm* (33) button
- Set the desired value with the *Minus/Plus* (32) buttons
- set value by pressing the *confirm* button (33) accepted

Unit

- Select the **Unit** menu item in the menu by pressing the *Minus button* (32), then press the *Confirm button* (33)
- Select unit of display: metric or imperial
- Set value by pressing the *Confirm button* (33)
- To change a unit, select the desired unit with *the Minus button* (32), then press the *Confirm button* (33)

Basic 229V
Machine Settings
< Settings
Data & Time >
Unit >
LCD Contrast [%] 89
LCD Backlight wh [%] 90
LCD Backlight rd [%] 90
Key Backlight

Basic 230V
Unit
< Machine Settings
Global Unit imperial
Unit Speed imperial
Unit Heat imperial

Basic 230V
Unit
< Machine Settings
Global Unit metric
Unit Speed metric
Unit Heat metric

Worklight

- In the menu, select the menu item **Work Light** by pressing the *Minus* (32) button, then press the *Confirm* (33) button
- Select the power-on mode of the working light: Motor Release, Always ON or Always OFF
- Then select the desired unit with *the Minus* (32) button, then press the *Confirm* (33) button
- set the intensity of the working light in % with the *Minus/Plus button* (32)
- accept the value set by pressing the *Confirm button* (33)

DPE Ø1 237V
Machine Settings
< Settings
Data & Time >
Unit >
Work Light >
LCD Contrast [%] 80
LCD Backlight wh [%] 85
LCD Backlight rd [%] 90

E Ø5nr 238V
Work Light
< Machine Settings
Motor Release ✓
Always ON
Always OFF
Brightness [%] 100

HDPE Ø 237V
Work Light
< Machine Settings
Motor Release ✓
Always ON
Always OFF
Brightness [%] 100

LCD Contrast

mm HE 237V
Machine Settings
< Settings
Data & Time >
Unit >
Work Light >
LCD Contrast [%] 80
LCD Backlight wh [%] 85
LCD Backlight rd [%] 90

- In the menu, select the menu item **LCD Contrast** by pressing the *Minus* (32) button, then press the *Confirm* (33) button
- the contrast can be adjusted using the *Minus/Plus button* (32)
- accept the value set by pressing the *Confirm button* (33)

LCD Backlight wh

E 51r	
237V	
Machine Settings	
< Settings	
Data & Time	>
Unit	>
Work Light	>
LCD Contrast [%]	80
LCD Backlight wh [%]	85
LCD Backlight rd [%]	90

- In the menu, select the menu item LCD Backlight wh by pressing the *Minus* (32) button, then press the *Confirm* (33) button
- the intensity of the white backlight can be adjusted using the *Minus/Plus* button (32)
- accept the value set by pressing the *Confirm* button (33)

LCD Backlight rd

mm HE	
237V	
Machine Settings	
Data & Time >	
Unit >	
Work Light >	
LCD Contrast [%]	80
LCD Backlight wh [%]	85
LCD Backlight rd [%]	90
Key Backlight	<input type="checkbox"/>

- In the menu, select the menu item LCD Backlight rd by pressing the *Minus* button (32), then press the *Confirm* button (33)
- the intensity of the red backlight is set by means of the *Minus/Plus* button (32)
- accept the value set by pressing the *Confirm* (33) button

Backlight button

5mm F	
236V	
Machine Settings	
Unit >	
Work Light >	
LCD Contrast [%]	80
LCD Backlight wh [%]	85
LCD Backlight rd [%]	90
Key Backlight	<input type="checkbox"/>
Remote Mode	<input type="checkbox"/>

HDPE J	
237V	
Machine Settings	
Unit >	
Work Light >	
LCD Contrast [%]	80
LCD Backlight wh [%]	85
LCD Backlight rd [%]	90
Key Backlight	<input type="checkbox"/>
Remote Mode	<input type="checkbox"/>

- Select the Button Backlight menu item in the menu by pressing the *Minus* (32) button
- Switch on or off the keypad light by pressing the *Confirm* (33) button.

Service Intvl. (h)

- In the menu, select the menu item Service Intvl. (h) by pressing the *Minus* (32) button
- Then press the *Confirm* button (33) and *Plus* button (32)
- by subsequently pressing the *Menu* (34) button, reset the hour counter to 0 for the Maintenance Service display

Basic 240V	
Machine Settings	
Work Light	>
LCD Contrast [%]	90
LCD Backlight wh [%]	85
LCD Backlight rd [%]	90
Key Backlight	<input type="checkbox"/>
Service Intvl. [h]	0
Remote Mode	<input type="checkbox"/>

Basic 240V	
Machine Settings	
Work Light	>
LCD Contrast [%]	90
LCD Backlight wh [%]	85
LCD Backlight rd [%]	90
Key Backlight	<input type="checkbox"/>
Service Intvl. [h]	<input type="checkbox"/>
Remote Mode	<input type="checkbox"/>

Basic 239V	
Machine Settings	
Work Light	>
LCD Contrast [%]	90
LCD Backlight wh [%]	85
LCD Backlight rd [%]	90
Key Backlight	<input type="checkbox"/>
Service Intvl. [h]	<input type="checkbox"/>
Remote Mode	<input type="checkbox"/>

Remote mode

Remote mode is currently inactive.

Reset to defaults

- Select the Reset to defaults menu item in the menu by pressing the *Minus* (32) button
- Then press the *Confirm* button (33) and *Plus* button (32)
- Reset all settings to factory default by pressing the *Confirm* (33) button

Basic 240V	
Machine Settings	
LCD Contrast [%]	90
LCD Backlight wh [%]	85
LCD Backlight rd [%]	90
Key Backlight	<input type="checkbox"/>
Service Intvl. [h]	0
Remote Mode	<input type="checkbox"/>
Reset to defaults	<input type="checkbox"/>

Basic 241V	
Machine Settings	
LCD Contrast [%]	90
LCD Backlight wh [%]	85
LCD Backlight rd [%]	90
Key Backlight	<input type="checkbox"/>
Service Intvl. [h]	0
Remote Mode	<input type="checkbox"/>
Reset to defaults	<input type="checkbox"/>

Basic 241V	
Machine Settings	
LCD Contrast [%]	90
LCD Backlight wh [%]	85
LCD Backlight rd [%]	90
Key Backlight	<input type="checkbox"/>
Service Intvl. [h]	0
Remote Mode	<input type="checkbox"/>
Reset to defaults	<input checked="" type="checkbox"/>

9.9 Info mode

Basic 236V	
☺☺☺	OFF °C 260
✂	OFF % 100
	Plast Motor 0rpm Heat 0% 24°C 24°C PLA 0% 35°C 240°C PLB 0% 34°C 280°C

Switched off at the factory

- If Info Mode is activated, additional information is displayed at the work level.

The following information is displayed:

- Speed Plast motor in rpm
- Heating fan; % heating capacity utilization and ACTUAL and TARGET temperatures in °C
- Heating Plast A; % heating capacity utilization as well as ACTUAL and TARGET temperature in °C
- Heating Plast B; % heating capacity utilization as well as ACTUAL and TARGET temperature in °C

Basic 231V	
Settings	
Eco Mode	>
LQS	>
Advanced Mode	<input checked="" type="checkbox"/>
WLAN	>
Machine Settings	>
Info Mode	<input checked="" type="checkbox"/>
Duty Info	>

Basic 232V	
Settings	
Eco Mode	>
LQS	>
Advanced Mode	<input checked="" type="checkbox"/>
WLAN	>
Machine Settings	>
Info Mode	<input checked="" type="checkbox"/>
Duty Info	>

- In the menu, select the menu item Info Mode by pressing the *Minus* (32) button
- Activate Info Mode by pressing the *Confirm* button (33).

9.10 Duty info

Basic 231V	
Settings	
LQS	>
Advanced Mode	<input checked="" type="checkbox"/>
WLAN	>
Machine Settings	>
Info Mode	<input checked="" type="checkbox"/>
Duty Info	>
General Info	>

Basic 235V	
Duty Info	
< Settings	
Hours Machine [h]	7
Hours Drive [min]	10
Hours Blower [h]	55

- Select the Duty Info menu item in the menu by pressing the *Minus* (32) button, then press the *Confirm* (33) button
- Run times of the machine, drive and blower are displayed

9.11 General Info

Basic 232V	
Settings	
Advanced Mode	<input checked="" type="checkbox"/>
WLAN	>
Machine Settings	>
Info Mode	<input checked="" type="checkbox"/>
Duty Info	>
General Info	>
Warnings	>

Basic 229V	
General Info	
< Settings	
Firmware HMI	V0.08
Firmware Machine	V0.08
Production Year	2020
Production Month	1
Production Day	1
Production Number	0000

- In the menu, select the menu item General Info by pressing the *Minus* (32) button, then press the *Confirm* (33) button

The following information is displayed:

- Softwareversion HMI and PCU
- Extruder Production Date
- Serial number

10. WELDPLAST 300 Warning and Error Messages

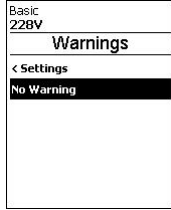

- In the menu, select the menu item Warnings by pressing the *Minus* (32) button, then press the *Confirm* (33) button

All warnings are now displayed.

If there is a warning pending, you can still continue to work largely without restrictions.

In contrast to the warning message, it is **not possible to continue working once an error message has appeared**. The heating is switched off automatically and the drive is blocked. The display of the corresponding error codes proceeds without delay in the working display.

Specific information about the type of error or warning can also be accessed from the Settings menu under Show Warnings.

Message type	Display	Error code	Description and measures
Warning		---	<p>Example of warning symbol in the status display (40)</p> <p>Supply voltage is too high At the same time, the red backlight of the LCD module is switched on alternately.</p>
Error		0020'XXXX	<p>Error symbol and note text (Error No. 0020/ Heater element defective) in the working display</p> <p>Solution: Replace the heating element</p>

Continue to next page

Message type	Display	Error code	Description and measures
Error		0002'XXXX	Undervoltage/overvoltage Solution: Check voltage source
		0004'XXXX	Hardware error ¹
		0008'XXXX	Thermocouple defective ¹
		0100'XXXX	Blower defective ¹
		0200'XXXX	Communication Module Fault ¹
		0400'XXXX	Drive Fault ¹

¹ Take a photo of the error message and contact your Leister Service Center.

11. Accessories

For more information please visit leister.com.

12. Maintenance



- Check the **power cord (17)** and plug for electrical and/or mechanical damage.
- Keep the appliance clean. Do not use aggressive substances when cleaning.
- Clean the **extruder nozzle (23)** each time the welding shoe is changed and remove the welding material residue (see chapter [Changing the welding shoe \[5.2\]](#)).
- Clean the **supply air filter (13)** regularly.

Caution: Clean the **supply air filter (13)** only when disassembled: To do this, use two size 3 or 4 screwdrivers to gently compress the **supply air filter (13)** in the recesses and pull the **supply air filter (13)** up. After cleaning, you can move the **supply air filter (13)** back to the initial position without tools. Once it snaps into place, the correct position is reached.

13. Service and repair

Repairs must only be carried out by authorized Leister sales and service partners. You can find the address of your authorized Leister sales and service partner on the last page of this manual.

For more information please visit leister.com.

For a safe change of the heating element [A1] and mica tube (Micatube) [A2], the following instruction applies:



Electrical Shock Danger - Protect yourself from electrical shock.

Before opening the device, unplug the device from the power outlet, as this will expose live components and connectors.



Danger of death due to improper change of the heating element [A1] and mica tube (Micatube) [A2]

- The change of the heating element [A1] and mica tube (Micatube) [A2] must be carried out exclusively by an **electrician**.
- Only **original accessories** and **spare parts** may be used.
- Make sure that the **mica tube (Micatube) [A2] has been reinstalled in good condition**, see step [9]. If necessary, the mica tube (Micatube) [A2] must be replaced.
- **A high voltage test [13]** must be performed after each change of the heating element [A1] and mica tube (Micatube) [A2].

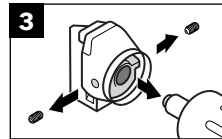
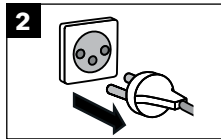
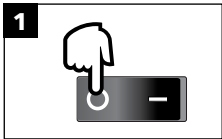

According to Chapter 5.2

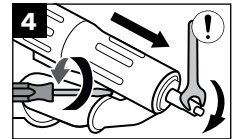

Note note ¹

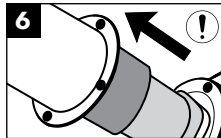
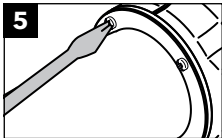

Note note ²

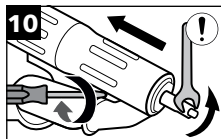
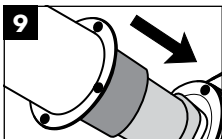
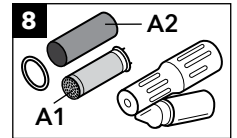
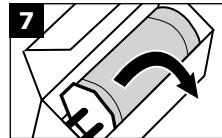

Note note ¹

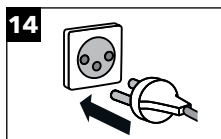
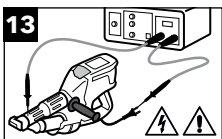
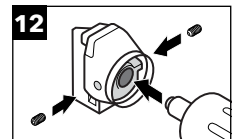
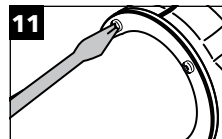

¹ **Note on Figure 4 and 10:** Note the left-hand thread of the nozzle. To disassemble, turn the nozzle clockwise with the open-end wrench, and counter-clockwise to install.

² **Note on Figure 6:** Note that you remove the heating element [A1] parallel to the probe so that you do not damage the probe, see step [6].

14. Training

The Leister Academy and its authorized Leister sales and service partners offer welding courses and product and service application training.

For more information please visit leister.com.

15. Other applicable documents

Extrusion Welders – Safety Instructions (part number: 175.858)

16. Declaration of Conformity

The Declaration of Conformity can be found on the website at leister.link/doc-weldplast-300



17. Disposal



Do not dispose of electrical equipment with household refuse.

Electrical appliances, accessories and packaging should be recycled in an environmentally friendly manner. When you are disposing of our products, please observe the national and local regulations.

Warranty

- The guarantee or warranty rights granted for this device by the direct distribution partner/salesperson apply from the date of purchase. In the event of a guarantee or warranty claim (verification by invoice or delivery note), manufacturing or processing errors will be rectified by the sales partner through replacement delivery or repair. Heating elements are excluded from warranty obligations or guarantees.
- Other guarantee or warranty claims are excluded within the framework of mandatory law.
- Damage resulting from natural wear, overload, or improper handling is excluded from the warranty.
- Devices that have been converted or modified by the purchaser are not covered by any warranty or guarantee.
- Only use original Leister spare parts and accessories; otherwise, any warranty or guarantee claims will be invalidated.
- In addition to your statutory warranty, Leister offers an extended warranty of up to 5 years from the date of purchase on Leister branded products (equipment and machinery) purchased through authorized dealers. To do this, register your product online within 30 days of the purchase date under leister.link/warranty.



Find a nearby dealer



Leister Technologies AG

Galileo-Strasse 10
6056 Kaegiswil
Switzerland

+41 41 662 74 74
leister@leister.com

leister.com

